

THIS DRAWING IS UNPUBLISHED. RELEASED FOR PUBLICATION 2013
 © COPYRIGHT 2009 TE CONNECTIVITY AMP ESPAÑA S.L.U. ALL RIGHTS RESERVED.

LOC 1K DIST 2

REVISIONS					
P	LTR	DESCRIPTION	DATE	DWN	APVD
	D	ADDED CABLE TERMINATION RANGE (NOTE 3)	05MAR2009	RM	JS

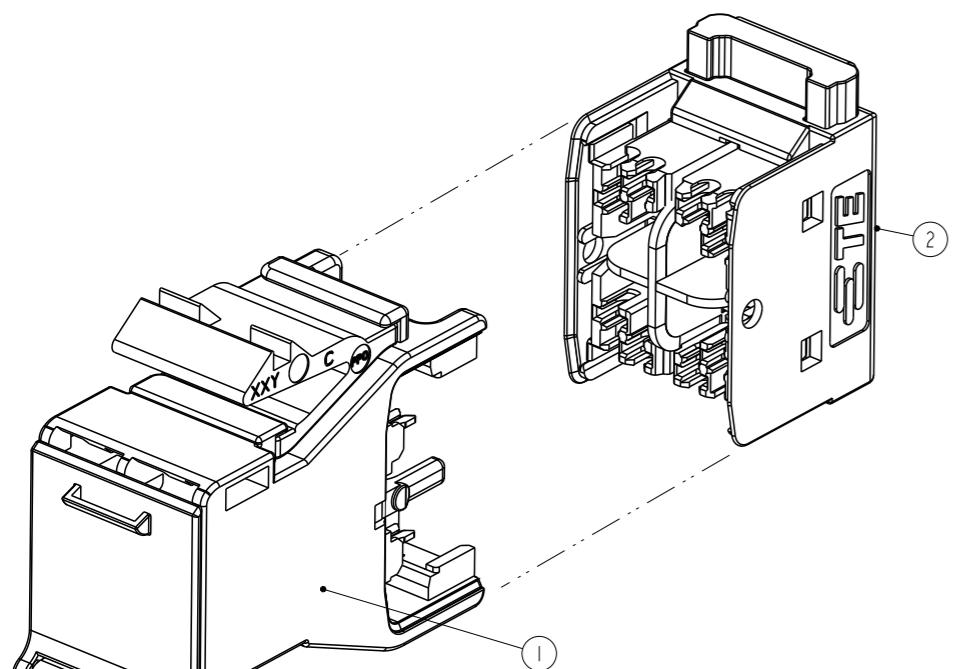

- ITEMS SHIPPED NOT ASSEMBLED.
- PACKAGING:
 DASH -1: EACH JACK IN A BLISTER BOX INCLUDING A INSTRUCTION SHEET 411-93013
 10 BLISTER BOXES IN A CARTON BOX (INCLUDING TWO TOOL SUPPLEMENTS).
 200 JACKS IN A SHIPPING BOX.
 DASH 7- -1: 24 JACKS (2 TRAYS + 1 INSTRUCTION SHEET PER BOX)
 PVC TRAY INCLUDING 12 JACKS. TWO PVC TRAYS IN A CARTON BOX
 WITH ONE INSTRUCTION SHEET 411-93013.
 360 JACKS IN A SHIPPING BOX.
- AMP-TWIST 7AS SL JACK WILL TERMINATE:
 - SOLID CONDUCTORS: 22-24 AWG.
 - MAX. INSULATION DIAMETER: Ø1.60 mm
 - MAX. CABLE JACKET: Ø9.00 mm

SCALE 2:1

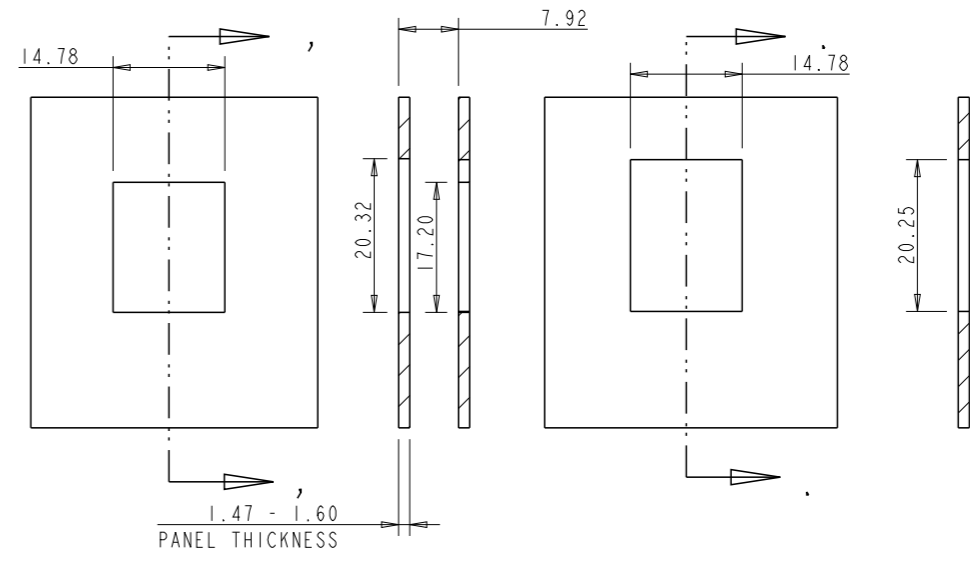
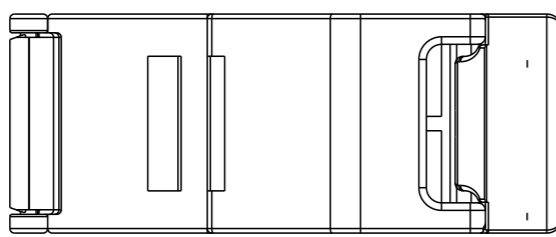

SUGGESTED FLUSH MOUNT PANEL APPLICATION CUTOUT SINGLE PANEL CUTOUT

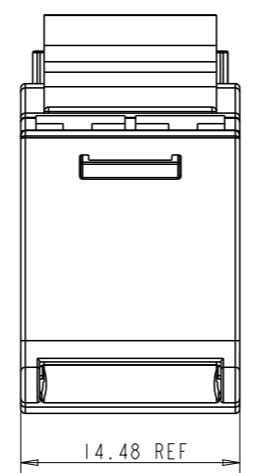
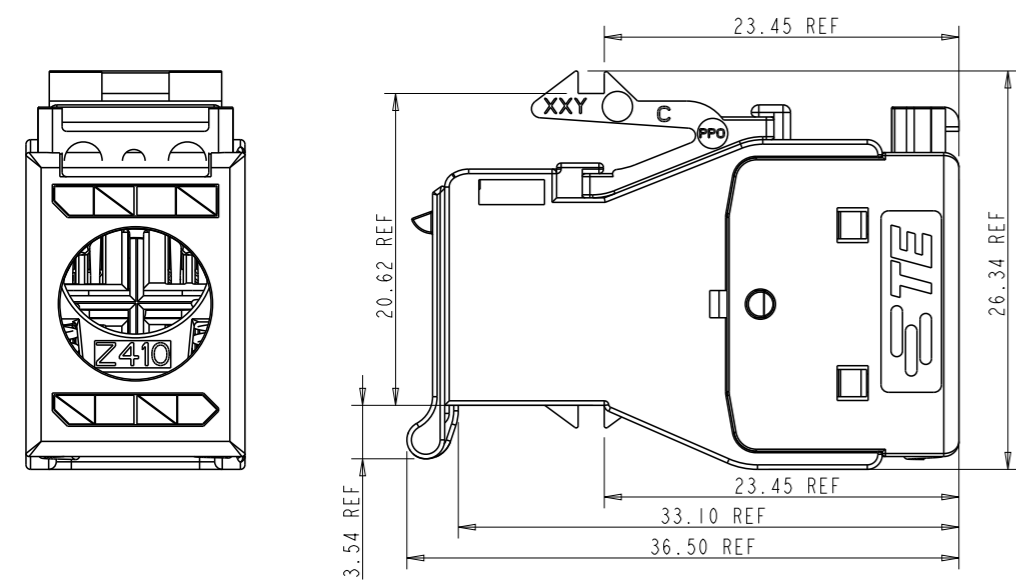

SCALE 2:1

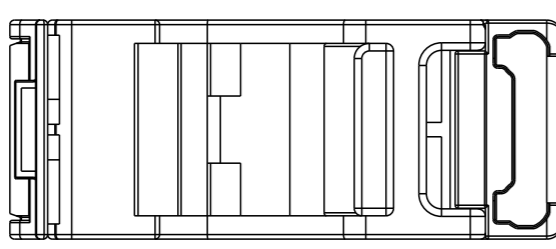

1	1	SUBASSY REAR HOUSING	2
1	1	SUBASSY FRONT HOUSING WITH DUST COVER	1
7--1	-1	DESCRIPTION	ITEM

THIS DRAWING IS A CONTROLLED DOCUMENT.

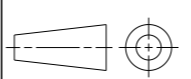
DWN R. MATEO 02MAY2007	 TE Connectivity NAME AMP-TWIST 7AS SL JACK WITH DUST COVER					
CHK A. PUELL 07MAY2007						
APVD J. SANABRA 13DEC2007						
PRODUCT SPEC 108-93019						
DIMENSIONS: mm	TOLERANCES UNLESS OTHERWISE SPECIFIED:	APPLICATION SPEC 411-93013	SIZE A3	CAGE CODE -	DRAWING NO C-1711441	RESTRICTED TO -
	0 PLC ±- 1 PLC ±- 2 PLC ±- 3 PLC ±- 4 PLC ±- ANGLES ±-	WEIGHT -	Customer Drawing	SCALE 1:1	SHEET 1 OF 1	REV D
MATERIAL -	FINISH -					